

Clay Non-Wovens

Robotic Fabrication and Digital Ceramics

David Rosenwasser

Dept. of Architecture, AAP,
Cornell University & Sabin Design
Lab, AAP, Cornell University

Sonya Mantell

Dept. of Architecture, AAP,
Cornell University

Jenny Sabin

Dept. of Architecture, AAP,
Cornell University & Sabin Design
Lab, AAP, Cornell University



1

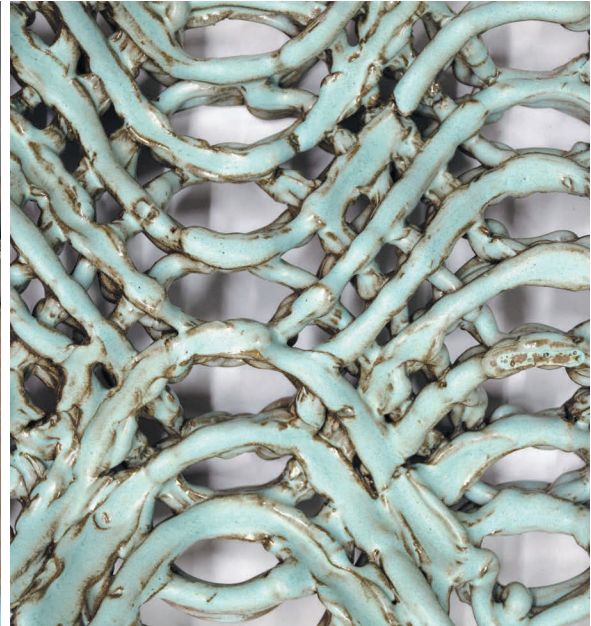

2

ABSTRACT

Clay Non-Wovens develops a new approach for robotic fabrication, applying traditional craft methods and materials to a fundamentally technical and precise fabrication methodology. This paper includes new explorations in robotic fabrication, additive manufacturing, complex patterning, and techniques bound in the arts and crafts. Clay Non-Wovens seeks to develop a system of porous cladding panels that negotiate circumstances of natural daylighting through parameters dealing with textile (woven and non-woven) patterning and line typologies. While additive manufacturing has been built predominantly on the basis of extrusion, technological developments in the field of 3D printing seldom acknowledge the bead or line of such extrusions as more than a nuisance. Blurring of recognizable layers is often seen as progress, but it does away with visible traces of a fabrication process. Historically, however, construction methods in architecture and the building industry have celebrated traces of making ranging from stone cutting to log construction. With growing interest in digital craft within the fields of architecture and design, we seek to reconcile our relationship with the extruded bead and reinterpret it as a fiber and three-dimensional drawing tool. The traditional clay coil is to be reconsidered as a structural fiber rather than a tool for solid construction. Building upon this body of robotically fabricated clay structures required the development of three distinct but connected techniques: 1. construction of a simple end effector for extrusion; 2. development of a clay body and; 3. using computational design tools to develop formwork and toolpath geometries.

- 1 Production of ceramic component system using woven and non-woven patterning.
- 2 Detail of a glazed Non-Woven panel with ordered geometry.

INTRODUCTION

In our study of non-wovens, we seek to investigate redundancy through overlaid lattices, variations of toolpaths, and the negotiation of material properties such as shrinkage and warping during a kiln firing process. Possible variations within toolpaths include line weights, degree of curvature (based on the sine curve), directionality, continuity, overlap, and distance between layers (Figures 1 and 2). This is achieved by carefully controlling the flow of pressure from an air compressor, which dictates the speed of extrusion. When this is done in excess (faster extrusion than movement of the robot), it creates either a thicker line weight or irregular looping behavior depending upon the distance between the previous layer and current extrusion. We are curious about this looping behavior as a productive tool for deviating from the standard deposition of regular linework. Throughout our testing, we explore the limits and strengths of using this deposition technique. Issues of structure arise, which give way to a parameterized patterning system that builds intelligence into a disordered series of patterns. In short, predictable irregularities can be programmed into each panel as an intentional pattern (Figures 3 and 4). Much like the process of felting in the textile industry, we depend upon adhesion through connection points, while also allowing for controllable moments of porosity. The module or produced panel itself enables a system for aggregation, offering a variety of possibilities for tessellation and formal differentiation. Using this system, we are able to create countless numbers of unique parts (Figure 5).

While earlier definitions of craftsmanship have only involved the human hand, digital tools raise the question of how to engage processes of ancient or traditional crafts through new means. With the advent of ABS and PLA (thermoplastics) as extruding materials for additive manufacturing techniques, makers are challenged with an accuracy that demands very little geometric renegotiation and where measurements can be predictably defined digitally with very strict tolerances. The craft of ceramics, dating back many millennia, has appealed to artisans and artists alike due to its workable plasticity, but also because of its unpredictable formal characteristics. The clay medium can be controlled and standardized for brick-making as an example, but that requires both consistent formwork and wall thickness. When this consistency varies or a form does away with uniformity, the material has the tendency to warp, move, and sometimes crack in spontaneous ways. Put in the context of digital fabrication, the material adds a series of parameters based more so in craft, which can be honed, refined, and learned, as we've seen in Hod Lipson's work with robots and painting. The results of this process may read as similar to something handmade, since the machine calibration is intended to produce irregularities (Figures 5–7). With continuing interest in complex structures and mass



3



4

3 Differing amounts of air pressure create varied line weights. Note the difference between patterns in foreground versus background.

4 By depositing material close to the surface of the previous layer, the resultant panel appears very similar to its programmed geometry.

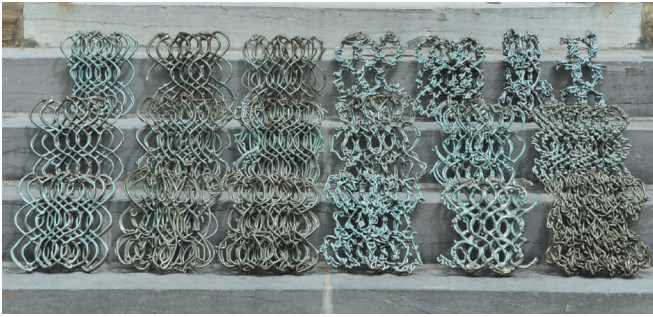

5



6

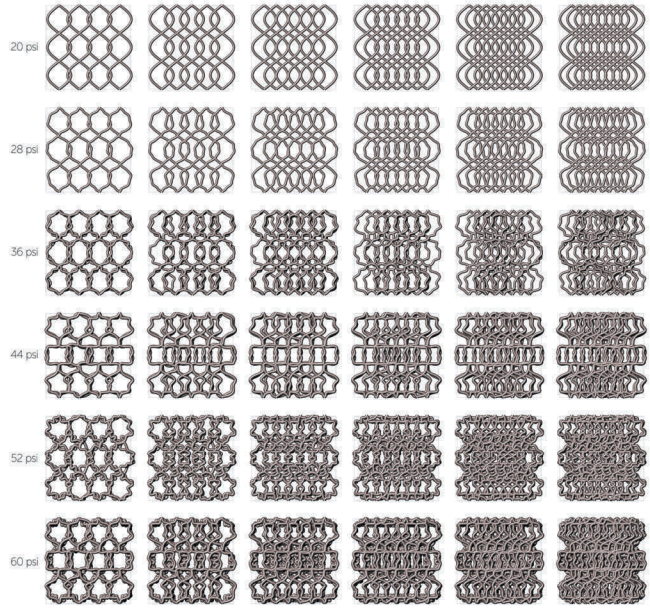

7

customization, we seek to employ the robotic arm to decompartmentalize complex, architectural-scale surface systems and subdivide the whole, but with tolerances that allow for expressive material response. The engagement of precise digital tooling is married with the playful nature of a clay body, provoking a response that can only be found within the realm of digital crafts.

Additive manufacturing typically involves the construction of objects through the continuous deposition of material, which builds up to form solid surfaces. The process of deposition allows the freedom to create a surface with possibilities for voids formed by absences. Less common point-based additive manufacturing is also used, where cellular structures are constructed to build lightweight forms, still recognizable by their defined shapes or bounding lines. Subtractive processes, such as CNC (computer numerical control) machining, allow for the manipulation of nearly any solid material, but can be severely restricted by reductive limitations such as undercuts and scale.

Our approach and vantage point is derived from that of textiles, where we are instead choreographing the movement, thickness, and expression of each length of a line or coil. The robot is our consistent tool, running through a program of toolpaths that we prescribe; however, human input decides how to design each component and how to create order (or lack thereof) within each panel. One could interpret this as an exercise of textile design, where the designer or human input is analyzing and designing each textile at the scale of atypically intimate 10 x 10 warp and weft threads. By challenging the material to create rigid

components via ordered and redundant structures, we depend on the fundamental concepts and rules of non-woven patterning to maintain continuity and coherence between layers.

This paper continues with an ongoing research trajectory in the Sabin Design Lab at Cornell University: the construction of building components constrained and expressed by an interest in digital craft and nonstandard building blocks. Noted first in the PolyBrick Series, the Sabin Design Lab sought to explore how 3D-printing technology can influence our built environment. PolyBrick 1.0 dealt with powder-based printing to create nonstandard blocks forming structural walls. More recent explorations engage structural bone formation and programmable matter through DNA glazing, but all using powder-based or stereolithography technology. By shifting upward in scale to the fabrication capabilities provided by a 6-axis robotic arm, and also increasing scale and attention to each individual layer, we dramatically shift this focus of the nonstandard to address nonstandard patterning in conjunction with mass customizable forms.

Our mission is as follows. 1. Create a mass customizable screen system, whose porosity can be parametrically controlled (based on conditions such as daylighting), implementing natural, readily available, and reusable building materials. 2. Develop an extrusion system catered toward the often troublesome material properties of a clay body, which will allow for independent exploration of varying clay mixtures, densities, feeds and speeds, and coil size. 3. Design a series of methodical tests and experiments

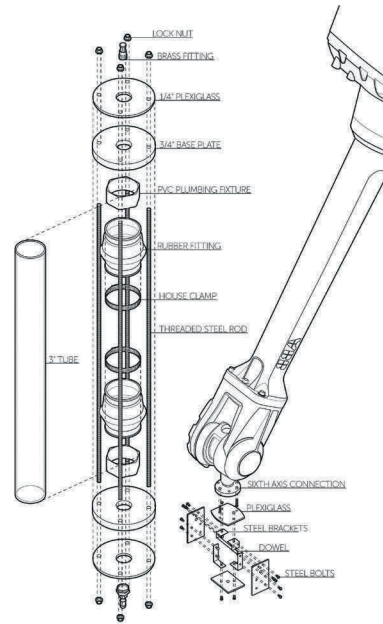
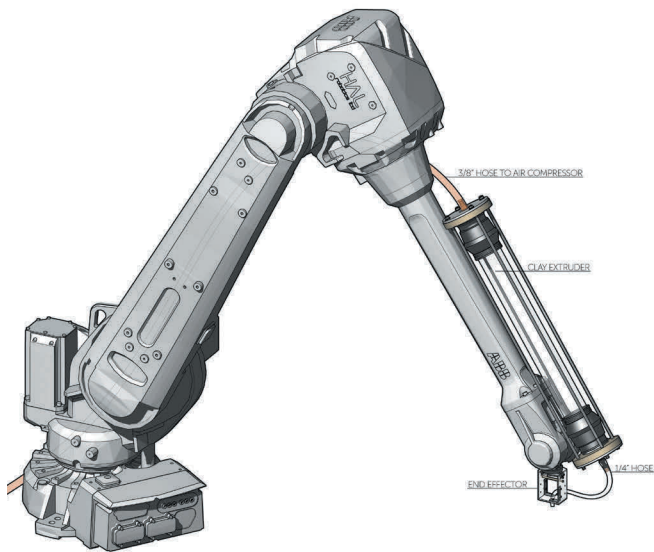

- 5 A variety of final prototypes, all exhibiting unique patterns from one another. Some read as porous and ordered, while others read as dense and/or disordered.
- 6 Looping behavior, which occurs as a result of depositing material 0.5–2 inches above the surface of the previous layer.
- 7 Rendered image of expected patterning. The intent and realized result was to produce 36 panels, which transitioned from highly structured and porous to disordered and dense.
- 8 Drawing of end effector design. Device was made entirely from parts readily available from a hardware store, along with a polycarbonate tube.

8

that identify the constraints of our toolpaths as they relate to a variety of formally different surfaces.

BACKGROUND

Background: Non-Wovens

Non-wovens define a category of fabrics that depend upon neither the weaving or knitting process. Contrary to the systematic precision involved to weave through warp and weft, non-wovens result from the compression of somewhat randomly oriented fibers becoming entangled chemically, thermally, mechanically, or by human force. Hydroentangling, needle punching, and thermal bonding are three of the main processes used to produce a non-woven fabric. It does not require conversion of fibers into yarn. Instead, it depends upon short staple fibers and/or long continuous fibers. This process is sometimes preferred because of its cheaper price, facility of production, filtration properties, lighter weight, and function for insulation.

This project explores an interest in transitioning from non-woven to woven patterning within the context of robotically fabricated non-standard clay components. Via careful attention to process and detail, we seek to produce a screen system that emphasizes a clear visual reading of this gradient and acts as a case study for developing varying systems of clay non-wovens and felting more specifically. Within the realm of digitally fabricated clay structures, little documentation of felting seems to exist yet in an academic or industry publication (Figures 10 and 11). We find this opportunistic, in that clay has a makeup of material properties that resonate with the felting process in ways that

may be more successful than the use of typical fibrous material. For example, felting of fibers requires considerable amounts of energy and resources in the process of compressing fibers. Deposition of clay requires no additional compressing force, as the pressure of gravity causes enough adhesion to bond each layer of clay together.

Background: Clay Extruder

In exploring the territory of clay deposition, it is critical to note that many institutions and independent offices have rigorously explored the potential of this material, whether through robotically steered or more typical additive 3D printing techniques. This includes Ron Rael and Virginia San Fratello of Emerging Objects, the Harvard Graduate School Of Design, Fablab Torino, and many others. Several designers and a select group of institutions have recognized clay's potential in our digital age and its historical impact on the built environment. Ron Rael and Virginia San Fratello have experimented with additive processes that engage glitch, using gravity as a tool for complex surface patterning through their additively constructed vessels and architectural-scale works such as Seed Stitch. The IAAC (Institute for Advanced Architecture of Catalonia) has been instrumental in developing robust end effectors for their additive works. Their FabClay project demonstrated how store-bought parts, mostly plumbing fittings, could be used to build a simple end effector. Friedman, Kim, and Mesa, however, of Harvard's GSD, were able to apply this technique to experiment with fabric structures and differentiate Woven Clay by minimizing the number of printed layers and increasing the size of their extruded coil.

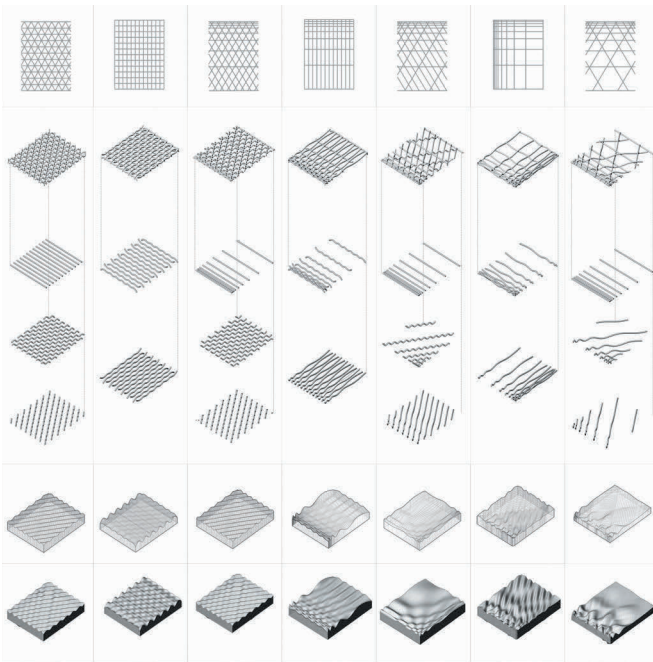

9

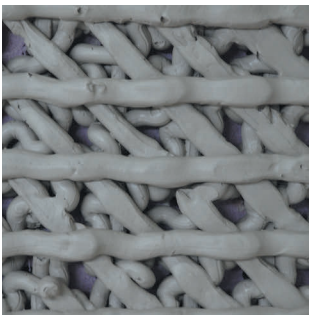

10



11

9 Deposition linework and its relationship to possible formworks below.

10 Example of "felted," resulting from varied air pressure and deposition height.

11 Increased pressure produces more accentuated looping behavior as compared to image beside. Note the straight versus looped line weight. This is a result of increased pressure (higher PSI from air compressor).

Industrial designer Olivier Van Herpt shows us how custom-made yet simple machines such as his delta-bots can produce pieces of uncompromisingly high quality. Van Herpt builds his own extruders and 3D printers, which produce an array of fireable patterned ceramic vessels. Arguably more relevant is the care and attention to detail inherent to his machines, which maintain quality control and transform the machine into sculpture.

Harvard GSD's Woven Clay, published for ACADIA 2014 carried with it a series of innovations and also curious nuances. The authors made use of a 6-axis industrial robotic arm to deposit clay and eventually create a series of rectangular panels, varying

in porosity. While creating an overlaid lattice was successful, no evidence of a truly woven structure existed. A weave consists of warp and weft threads, where the weft (horizontal in the case of a loom) thread passes over and under the warp (vertical) to hold the warp in tension. All weaves share this relationship of threads existing over and under, noting that the weft is typically continuous. Put simply, the patterning in Woven Clay is always going over, but never under, and is therefore not truly woven. While this was by no means problematic, we saw this as an opportunity to deviate from their structure and seek out ideas such as felting within the realm of non-wovens. Woven Clay chose to construct panels on CNC-milled formwork and cut edges to improve predictability for assembly. Woven Clay's video also shows considerable modifications done by hand. We sought to work with the challenge of a continuous bead or thread and consider the intelligence of non-woven fabrics that depend on natural adhesion from layer to layer rather than tension.

Lastly, the digifabTURING lab based at FabLab Torino teaches us about how end effectors can be constructed for clay extrusion and how clay can respond to digitally fabricated formwork through what they call "Experimental Materiality." The digifabTURING lab has iterated through a variety of end effectors, beginning with materials like plywood and polycarbonate tubes, then transitioning to a system that depends upon a more minimal single-piece metal chamber with machined sealing caps to ensure proper containment of the clay. With this device, the lab produces vessels, patterns on fabric formwork, and various other formal experiments.

METHODS

Methods: Extruder

To expedite the process of constructing a clay-extruding end effector, we researched existing devices and eventually expanded our search to include robotic end effectors and delta-bot dependent chambers. We discovered that clay extruders typically involve compressed air, stepper motors, or a combination of the two. Stepper-motor-driven solutions involve a threaded rod and geared system, which plunges clay through a nozzle on one end. These examples are well controlled and can be adjusted using an Arduino board, but are restrictive in that their chambers are typically mounted vertically (which hinders use of a 6-axis robotic arm) considering that the threaded rod needs to extend one full length past the top of the extrusion chamber.

Pneumatic systems, on the other hand, involve forcing air into an enclosed tank, which pushes clay through a nozzle after ample pressure is applied. These examples are less controlled and often lend themselves to extruding with continuous beads since there is a delay between stopping the flow of air and halting

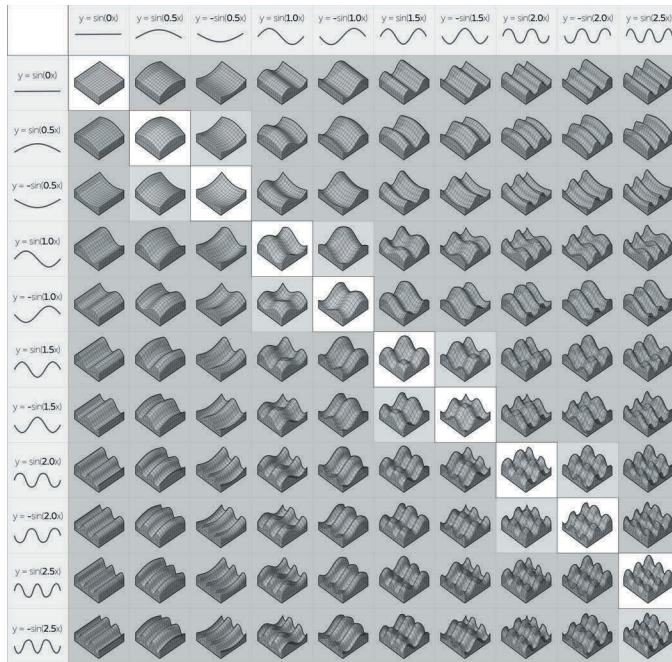

12 Matrix drawing of formwork iterations, beginning with gentle curves and then increasing in complexity. This process was used to test material limitations.

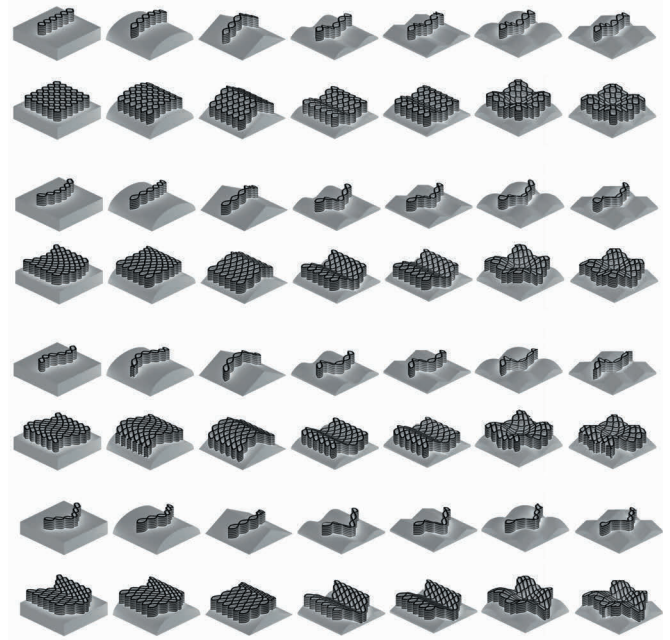

13 Drawing to show how deposited material correlates to formwork. By designing both formwork and pattern, we were able to carefully work with material behavior.

the flow of clay. The noteworthy benefit of pneumatic-only systems is that little is involved other than a tightly sealed tank, air compressor hose, and well-fixed nozzle. It does not require the aid of Arduino boards, but can be modified to add greater functionality.

Secondary iterations are often found alongside simple pneumatic systems, which add the use of an auger valve to direct flow. This keeps flow more consistent by using an Arduino board and stepper motor to control speed of rotation for the auger and therefore control flow rates of the extrusion. The augers we studied ranged in size from half-inch drill bits to bits the size of baking mixer blades, depending on the scale of each project. By adding an auger instead of a threaded rod for plunging, the need to double the end effector's length is no longer necessary.

Electrovalves can be used for the purpose of simple starts and stops. These valves are commonly found in sprinklers and may be one of the simplest options for adding functionality to a clay-extruding end effector. After an extensive research process for the construction of prototypes, we decided to move forward with a purely pneumatic end effector, as our project aimed to use a continuous line and did not demand any additional functionality (Figure 8).

Methods: Software

Fabrication and prototyping of our paneling system utilized a relatively streamlined process of digital tools in order to translate

geometry and linework into physical tests. A continuous curve was first generated in Rhino, baked via Grasshopper script or drawn manually. This curve was then applied to a script in Grasshopper, which allows the user to adjust parameters such as subdivision number (how many points make up the continuous curve), robot model, dimensions of end effector, and various other factors. This script depended upon HAL, a plugin for Grasshopper used for robot programming and control. HAL allows those with access to a 6-axis industrial robot to quickly translate their geometries into rapid code. HAL also incorporates 3D models of various robots by ABB and KUKA, and can facilitate simulation for the purpose of testing. The robot we used for testing was an IRB 4600 by ABB with horizontal reaches of 2.05 meters and payload capacity of 45 kg. After generating rapid code in Grasshopper, the data is brought into ABB's programming software RobotStudio. Once in RobotStudio, little is necessary aside from creating a module with the appropriate robot and adjusting speed or starting position.

Methods: Formwork

The material properties of our selected clay body (Standard Ceramics No. 266 with water added) responded well to a variety of surface conditions or formworks made from construction-grade foam insulation material. With this noted, we produced a series of base forms with variations in curvature (domes, arches, peaks, etc.). We sought to use multiple formworks (figures, 9, 12-13) with shared connection types in order

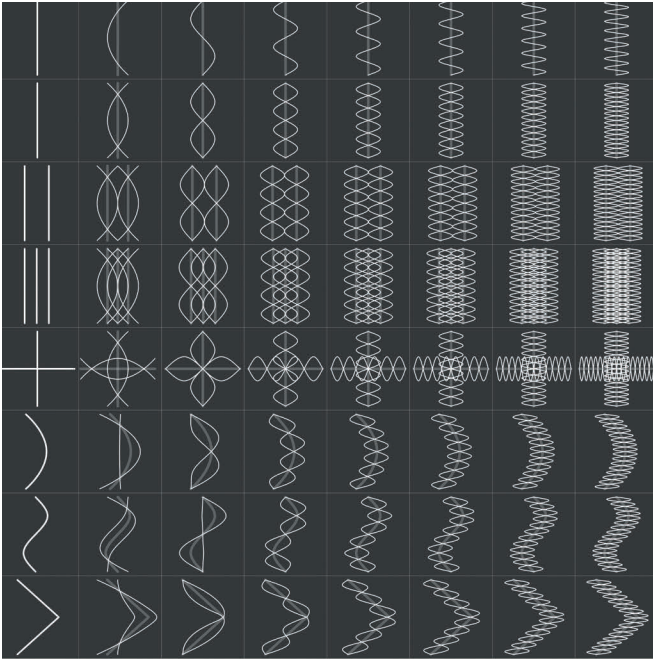

14



15



16

- 14 Linework tests to identify clay and robot limitations when challenged with sharp curves or tight patterns.
- 15 Rare instance of panel with high porosity but also showing distinct irregularity. This example has minimal edge conditions, where two layers of clay have bonded in select spots, resulting in increased strength.
- 16 Non-Woven panel, which is extreme in both density and irregularity. This piece uses more material than is needed to survive the firing processes, but utilizes the excess and looping behavior to prevent ight filtration.

to create an overall screen system with more complex underlying geometries. The intent was to design a limited number of base forms, which can be continually reused (Figure 14).

Methods: Creation Of Toolpaths

The creation of successful toolpaths is dependent upon digital calibrations, mathematical calculations, and reactions of material properties through physical testing. The formation of a line in our virtual world will eventually be translated to an extruded clay coil, which brings about an extensive series of material parameters that cannot necessarily be predicted virtually or parameterized within a script. The line is therefore

a suggestion and not a direct translation onto the constructed parts. This negotiation of precision became our key departure point, where the accuracy (or lack thereof) of simple and complex linework helped to direct our path for iterative testing (Figure 14).

Toolpaths were first developed in tandem with our earliest end effector extrusions, as this allowed us to test calibration and general precision. These early toolpath matrix drawings (Figures 12–14) build upon one another. They act as categorical proof of concept, hoping to define our physical limitations in a methodical manner. The drawings and their resultant toolpaths address questions of desirable material thickness, overlap tolerances, material strength, and realizable curve accuracy. Toolpaths were calibrated and perfected by creating an analogically driven formula that accounts for the speed of the robot's movement and extrusion speed based on pressure applied from our pneumatic system. With layering involved, considerable testing was required to perfect adhesion between layers without compromising the coils. Human error and imperfections in our clay bodies should also be acknowledged as factors.

Eventually applying these toolpaths to three-dimensional formworks, the development of whole dynamic components finally became realizable. Eighteen forms were CNC-milled, optimized for material usage and using each form to test limitations. Much like we examined the lines themselves, formwork was used to test response to lines and patterning such as adhesion to forms, sharpness of angles, movement during shrinkage, and reliability of certain shapes or curves. As one example, we found that sharp ridges are not ideal, as they act as cutting points in contrast to gentle peaks and valleys.

Calibration and its desired effect is essential to Clay Non-Wovens, in that the line weight and curve realization often varied dramatically from the digitally drawn curve. Such intentional guiding, as in Rael San Fratello's glitched vessels, can carry a structural expression and functionality of its own. Toolpath tests also allowed us to discover the minimum extruded line thickness and minimum number of connection points required to keep a piece intact without breakage during the production process (two layers resulted in occasional breaks, three layers for consistently stable results). Porosity, we found, could be negotiated with structured toolpaths containing precise overlap points for most minimal but strong parts (Figure 15). For denser panels, redundancy could be implemented for added structure, meaning more freedom in line expression (Figure 16). It should be noted that a series of environmental conditions contribute to the success or failure of each piece before kiln firing such as drying time, clay viscosity, and humidity of the production space. Similarly important is that each component gains considerable strength after bisque firing and far more after glaze firing. The system, however, has not been tested to identify load-bearing capacities.

Methods: Designing A Clay Body Recipe

Correctly calculating the viscosity and strength of our clay body was essential to the success of each non-woven panel. If clay is too rigid, its lack of pliability will lead to air redirecting itself to other parts of the



17 Clay crater created when air gap forces high air pressure onto surface of the clay.

containment chamber and cause an explosion of air pressure, bursting the hard rubber fittings that capped our polycarbonate tube. If clay is too soft, it will extrude uncontrollably and fail to find strength for multiple layers stacking upon one another.

Furthermore, the properties of each individual clay body type can vary drastically. Fine porcelain has exceptionally low plasticity and fine particles in its make up, which lead to delicate formal possibilities and exceptional hardness once fired. On the other hand, less fine materials containing substantial quantities of grog can be more appropriate for preventing cracking and reducing shrinkage. While grittier in their nature, clays containing grog are often more forgiving when handling different water contents and more likely to keep their form when faced with sharp edges or tight radii. Our clay tests first challenged a question of foundation; bagged clay or powder base? Bagged clay is pre-mixed and typically free of air bubbles. Dry powder clay requires water, but can be carefully mixed until its viscosity is satisfactory. We found that both options were feasible, but that bagged clay had many more available clay types, which allowed for control of color and plasticity. Both clay foundations required mixing with added water, as out-of-box properties were not satisfactory for immediate extrusion. After testing a range of options from powdered ball clay (gritty and unrefined) to porcelain (expensive and overly sensitive), we eventually settled upon a Dark Brown 266, which we bisque to Cone 06 (1825°F) and glaze to Cone 5 (2167°F). After glaze firing, the clay is smooth and dark, with larger clay particles than found in porcelain but not “toothy” or gritty due to grog by any means. This 266 clay by Standard Ceramics in nearby Pennsylvania is workable and terrifically consistent. This clay was cut into 1 to 2 pound pieces, with 1.5 gallons of water added to each 50-pound bag of clay. This clay was mixed using a

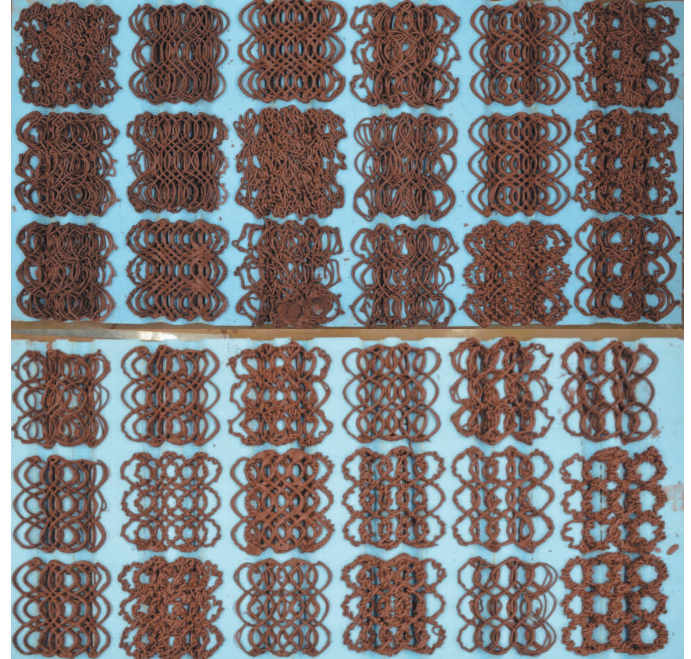

18 Variety of panels produced for final testing (36 in total). Dense above and porous below.

power drill and contained within a lidded 5-gallon bucket to help prevent evaporation. Glaze was applied using a spray gun in order to coat the panels evenly, increase strength, and avoid coating the undersides so that the panels could be kiln-fired vertically.

REFLECTION

In the continuing phases of this project, we seek to resolve discrepancies in the production of nonstandard components and reduce waste. Formwork can potentially be replaced by blocks that can be manipulated, printed upon, and reworked. Modeling clay, a commonly used material in the automotive prototyping practice, could be a suitable choice for the production of molds with fine finish qualities. By adding functionality to our end effectors such as tool changers and scrapers, greater intelligence can be imbedded into the fabrication process. This would enable the production of nonstandard geometry and patterning with zero waste.

Another very clear direction for this project is the engagement of Arduino controllers for the monitoring and control of pressure. Rather than a manual manipulation of pressure and therefore line weight, the designer can be more deliberate and can experiment with finer levels of precision. Valves are readily available to control the flow of air and auger feeds with stepper motors can control speed on the feeding end. For production at large scale (Figure 18) with minimal need for manual labor, a much larger chamber to hold clay would be ideal. In theory, 50 to 500+ pounds of clay could be stored nearby and extruded via tube. Our problem arose when transferring clay via tube, as the friction requires excessive pressure. With ample pressure and a tube of larger diameter, it seems more than feasible to have a secondary tank (not physically located on the

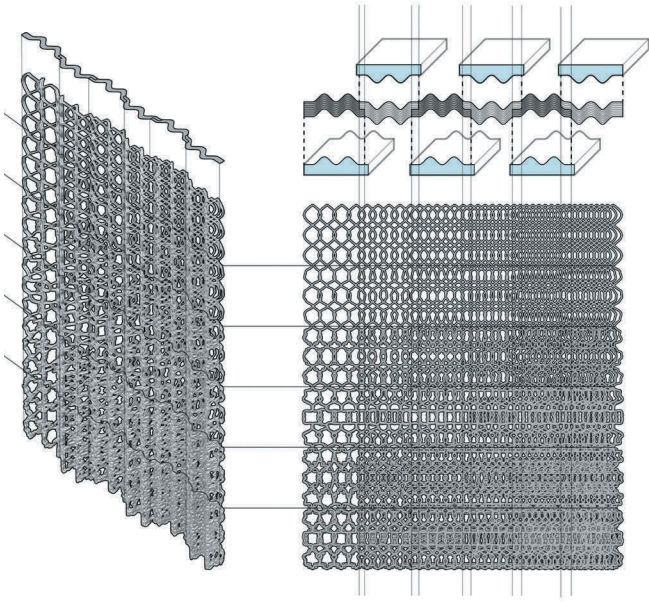

19 Prototype assembly strategy, using half lap joint and gradient of non-woven patterning to show porosity and chance in patterning.

robot). This tank would serve to transport clay into a more controlled but smaller extrusion environment, without added payload constraints to the robotic arm. A definite goal is the incorporation of a system that allows for continuous feed rather than constantly loading and reloading the clay chamber.

In the realm of scaling up and developing feasible systems for large-scale use, we feel that jointure between paneling has great potential, especially those such as the half-lap found commonly in woodworking. With numerous layers used during printing, thickness can reach a point quickly where the panels can arguably become structural or at least self-supporting.

As a cladding device and light filtration system, we have designed a process that produces an indefinite number of porous patterns while also allowing for the control of factors such as cross-sectional profile, level of porosity, and jointure between panels. The system is successful in this respect as a set of realizable parts with designed relationships to neighboring pieces, but has yet to be refined as a large-scale assembly with fasteners and load-bearing elements tested alongside. Continued research should push exploration of this system as applied to surface conditions such as an arch or dome. Variable and reusable formwork will also enable complex three-dimensional wholes to accompany the unique and porous parts.

CONCLUSION

The fabrication of textile-influenced structures via digital ceramics required rigorous experimentation and resulted in a series of informative discoveries. After choosing a pneumatic-only system for extrusion, we

found that pressure was perhaps the most influential factor in producing desirable and undesirable panels. To our surprise, clay responded well, but air in the clay body did not. Inconsistencies such as air bubbles produced gaps in the extrusion process, and creating air pockets toward the end of an extrusion (when the tank or chamber was nearly empty) produced clay craters from highly pressurized air releasing itself onto the finely deposited clay pieces. With reference to formwork and their responses, we found that formwork was a powerful tool for formal expression and also reliable for expressing three-dimensional geometries. As the production of these forms, however, was wasteful in its nature, we feel that there is great potential in the possibility for adaptable and/or recyclable replacements. Prototyping toolpaths first, followed by single panels and larger scale tests (36 panels), we were able to produce mass customizable componentry that addressed jointure and a gradient of patterning. The gradient produced dramatic results as a light filtering system, transitioning from ordered to disordered and dense to highly porous. This paper showcases one example of robotic fabrication processes, which foresee a future for the production of architectural assemblies with expressive irregularities in the context of digital ceramics.

ACKNOWLEDGEMENTS

This work is supported by the Department of Architecture, Cornell College of Architecture, Art and Planning, Cornell University.

REFERENCES

- Aguilar, Carlos and Lipson, Hod. 2008. "A Robotic System For Interpreting Images Into Painted Artwork." In *11th Generative Art Conference 2008*, edited by Celestine Soddu. Milan: Politecnico di Milano Generative Design Lab. 372–387.
- Boston Valley Terra Cotta and Machado Silvetti. 2016. "Glazed Ceramic Facade For Asian Art Center." In *The Architect's Newspaper Issue 2 2016* Edited by Jason Sayer. 1, 12.
- Bru gnaro, Giulio, Baharlou, Ehsan, Vasey, Lauren and Menges, Achim. 2016. "Robotic Softness: An Adaptive Robotic Fabrication Process for Woven Structures." In *ACADIA // 2016: Posthuman Frontiers: Data, Designers, and Cognitive Machines, Proceedings of the 36th Annual Conference of the Association for Computer Aided Design in Architecture*, edited by Kathy Velikov, Sean Ahlquist, Matias del Campo, and Geoffrey Thün. Ann Arbor: ACADIA. 143–163.
- Elashry, Khaled and Glynn, Ruairi 2014. "An Approach to Automated Construction Using Adaptive Programing." In *Robotic Fabrication in Architecture, Art and Design 2014*, edited by Wes McGee and Monica Ponce de Leon. Cham, Switzerland: Springer International Publishing. 51–66. doi:10.1007/978-3-319-04663-1_4.
- Fashami, Nasim, Jokić, Saša and Naya Lara, Starski. 2012. "FabClay: Robotic Additive Manufacturing Processes." *Designboom | Architecture and Design Magazine*. 2012. Institute for Advanced



20 Rendering, which shows one instance of how Clay Non-Wovens can be applied at an architectural scale for the purpose of light filtration.

Architecture of Catalonia. <https://www.designboom.com/readers/fabclay-robotic-additive-manufacturing-processes/>.

Friedman, Jared, Kim, Heamin, and Mesa, Olga. 2014. "Experiments in Additive Clay Depositions-Woven Clay." In McGee, Wes and Ponce De Leon, Monica, *Robotic Fabrication in Architecture, Art and Design 2014*, Springer International Publishing Switzerland. 261-272.

Graziano, Andrea and Erioli, Alessio. Informed Clay Matter, Film. Directed by CO-DE-IT, Fablab Torino, Office Arduino, COMAU, Toolbox Coworking. In *ROB|Arch 2016*. 2016. Sydney, Australia.

Hoffman, Guy and Breazeal, Cynthia. 2004. "Collaboration in Human-Robot Teams." In *American Institute of Aeronautics and Astronautics 1st Intelligent Systems Technical Conference*. Chicago, IL: AIAA. doi:10.2514/6.2004-6434.

Menges, Achim and Knippers, Jan. 2015. "Fibrous Tectonics." *Architectural Design* 85 (5): 40-47. doi: 10.1002/ad.1952.

Pigram, Dave and McGee, Wes. 2011. "Formation Embedded Design: A Methodology for the Integration of Fabrication Constraints Into Architectural Design." In *Integration Through Computation: Proceedings of the 31st Annual Conference of the Association for Computer Aided Design in Architecture*, edited by Joshua Taron, Vera Parlac, Branko Kolarevic and Jason Johnson. Banff/Calgary, Canada: ACADIA. 122-131.

Rael, Ron and San Fratello, Virginia. 2011. "Developing Concrete Polymer Building Components for 3D Printing." In *Integration Through Computation: ACADIA 2011 Proceedings*. 152-157

Sabin, Jenny, Miller, Martin, Cassab, Nicholas and Lucia, Nicholas. 2014.

"PolyBrick: Variegated Additive Ceramic Component Manufacturing (ACCM)." *3D Printing and Additive Manufacturing* 1 (2): 78-84.

Van Herpt, Olivier. "Functional 3D Printed Ceramics." Studio Olivier Van Herpt. <http://oliviervanherpt.com/functional-3d-printed-ceramics/>.

Willmann, Jan, Gramazio, Fabio, Kohler, Matthias and Langenberg, Silke. 2012. "Digital by Material: Envisioning an Extended Performative Materiality in the Digital Age of Architecture." In *Rob|Arch 2012: Robotic Fabrication in Architecture, Art and Design*, edited by Sigrid Brell-Cokcan and Johannes Braumann. Vienna: Springer-Verlag. 12-27.

IMAGE CREDITS

All image credits to authors (2017).

David Rosenwasser is a research and design associate in the Sabin Design Lab at Cornell University and a 5th year B. Arch Student in Cornell AAP's Department Of Architecture. He is also a Hunter R. Rawlings III Presidential Research Scholar.

Sonya Mantell is a 5th year B. Arch Student in Cornell AAP's Department of Architecture. She has worked in various architectural offices including AZA and Weston Baker Creative Group.

Jenny Sabin's work is at the forefront of a new direction for 21st century architectural practice — one that investigates the intersections of architecture and science. Sabin is the Wiesenberger Assistant Professor of Design and Emerging Technologies and Director of Graduate Studies in the Department of Architecture at Cornell University. She is principal of Jenny Sabin Studio and director of the Sabin Design Lab at Cornell AAP.